

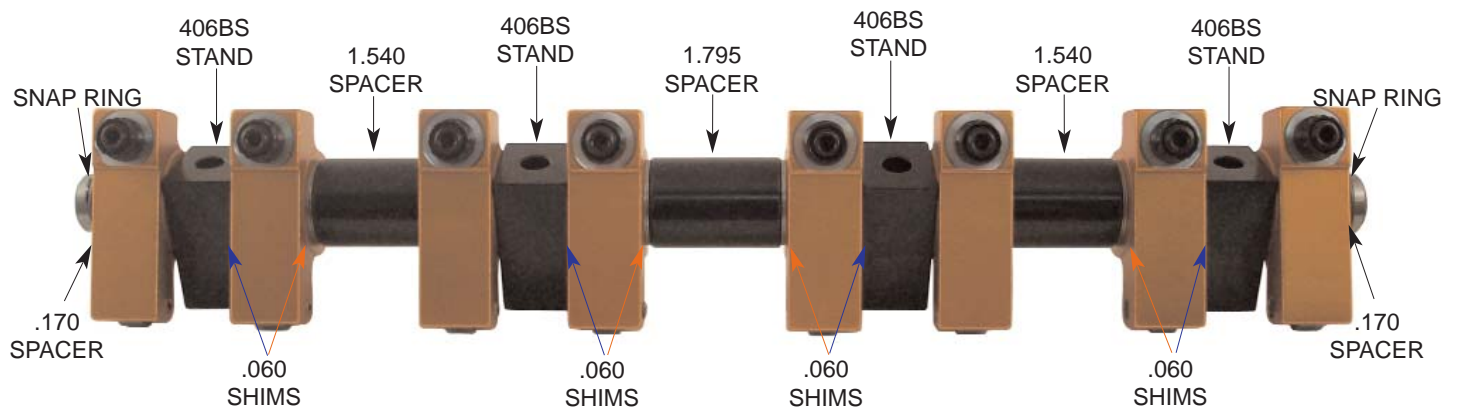

## Part # S4006BK

This high quality rocker kit includes heavy wall, specially hardened rocker shafts, bronze bushed roller rockers with adjusters & 12pt. jam nuts, billet steel stands and spacers. For ease of installation we included a diagram of the rocker assembly with proper placement of the components.

**Edelbrock Head** **Stock Head 390-427-428**  
 Colored arrows indicate where the shims need to be for the Edelbrock & Stock head 390-427-428



### Replacement Parts:

- 16 pcs. - 4006B-1 rocker arms
- 2 - 4006S-1 shafts (.840 dia.)
- 1 - 406BSK stands (4 pcs.)
- 1 - 406BSPK spacer kit (10 pcs.)
- 1 - 406BEK end stands (4 pcs.)
- 4 - FA716K adjusters & nuts (16 pcs.)

Spacers may need trimmed. **Make sure the oil holes in the shaft are on the bottom side of the rockers.**

### HS also recommends the following installation tips.

- For Edelbrock head install .060 shim between Int rocker & stand
- Oil adjusters and install into rockers before bolting to engine. Leave adjusters loose.
- Apply oil or lube to roller tip and pushrod ball before installing on engine or allow rocker assembly to soak in 30W oil for 1/2 hour prior to install.
- You want approximately .008 to .012 clearance gap per cylinder (bolt to bolt)
- Torque rocker hold down bolts to 25 ft. lbs.
- DO NOT OVERTIGHTEN!**
- Hand tighten adjuster jam nut or do not exceed 18-20 ft. lbs.
- DO NOT OVERTIGHTEN!**

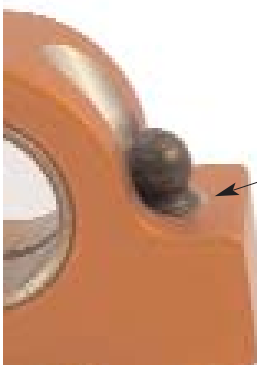

The rocker adjusters are a 7/16-20 screw with a 3/8 ball. You have to use pushrods with a 3/8 cup end. When setting pushrod length have no more than 2 and no less than 0 threads showing on the bottom side of the rocker, between the ball and rocker body. This is to make sure the pushrod contact point and rocker geometry are correct.

If you need assistance with this please contact our tech support @ 440.238.3260 M-F 7am to 4pm EST. Thanks